

# Estimation of Adulteration in Mustard Oil by Using Palm oil and soya oil as Adulterant with focus on Dielectric Properties

1<sup>st</sup> Marut Dev Sharma  
Assistant Professor ,Deptt.of  
Electrical & Computer Engg, Mada  
Walabu University  
Bale Robe, Ethiopia  
<https://orcid.org/-0000-0001-5456-9516>

2<sup>nd</sup> Dr. Parmod Kumar  
Associate Faculty, School of Energy  
and Electomechanical Engg, Hunan  
University of Humanities, Science &  
Technology, Hunan Province, China  
[dr-kumar2019@yandex.com](mailto:dr-kumar2019@yandex.com)

3<sup>rd</sup> Dinku Worku  
Lecturer, Deptt. of Electrical &  
Computer Engg, Mada Walabu  
University Bale Robe, Ethiopia  
[dinku.w19@gmail.com](mailto:dinku.w19@gmail.com)

4<sup>th</sup> Basam Koteswararao  
Lecturer, Deptt. of Mechanical Engg,  
Mada Walabu University  
Bale Robe, Ethiopia  
<https://orcid.org/0000-0001-5519-6432>

**Abstract**— Vegetable oils are used as cooking or frying medium for food products. Mustard oil adulterated with palm oil, soya oil and cheap industrial solvents causes gall bladder cancer, dropsy, glaucoma and loss of eye sight. The adulteration of vegetable oils are now a common practice in under developed countries like India, due to financial gain arising from different taxes that are imposed by the authorities. This work explores a new method for the estimation of adulteration in vegetable oils like mustard oil using its dielectric properties. The result shows that with a slight variation in the composition of the oil, the dielectric property varies significantly by the adulterated mixture. But adulterated oil when used by people has a significantly negative effect on their health and immunity system.

**Keywords**—Adulteration, Loss Index, Dissipation Factor, Blending Agents, Fuel Cell, Guard Rings Introduction

## 1 ADULTERATION

### 1.1 DEFINITION

It is the method of blending a cheaper product to a high value of product and targeting is for economic benefits. It implies concern on health of human being & environmental implications. This method gives an inferior final product and often exploits the incentives from poor. Palm oil is commonly used adulterant for mixing with vegetable oils. Adulteration of petrol and diesel with lower-priced materials is common in India as elsewhere in the world. Most of adulterants increase secretion of bad pollutants from tailpipe of vehicles, causing urban air pollution conditions severe [1].

### 1.1 Different Adulteration Types

There are various specific classes of adulteration [2]:

#### 1.2.1 By adding single raw material

This type of adulteration can be divided into two categories

- a) Invisible materials
- b) Visible materials

Invisible materials are not detected by using gas chromatography testing analysis working in routine way to analyze vegetable oils. Example: addition of low grade edible oil to vegetable oils. Rape seed is particular cheap oil used for this purpose.

Visible are those materials detected by gas chromatograph. Example: visible diluents utilize solvents and perfumery liquids. In adulteration procedure, the adulterant liquid is sort of diluent which does not emit its own odour in the mixture. By mixing up to 10 % of an adulterant is very difficult to be noticeable.

#### 1.2.2 Blending of low cost edible oils

Mixing of low cost oils to satisfy a customer's purchasing capacity price or to achieve good incentive for the manufacturer, but common adulteration used are bergamot oil (citrus bergamia), cinnamon bark oil, clove bud oil (syzygium aromaticum), grapefruit oil (citrus paradise) lemon oil (citrus lemon), peppermint oil (mentha X piperita) rosemary oil (rosmarinus officinalis).

#### 1.2.3 The blending of cheaper (nature identical) synthetics

A very few detailed regulations has been previously published in this area.

### 1.2 Classification Of Adulteration

The adulteration may be widely classified as follows:

- Mixing of cheap Palm oil into mustard oil.
- Mixing of some industrial solvents into mustard oil.
- Mixing of cheap soya oil into mustard oil.
- Mixing of very Cheap Rice Husk Oil into Mustard oil.

### 1.3.1 Characteristics of Adulterants

Adulterant must have the following characteristics:

- Ensures higher financial gains (profitable).
- Easily available.
- Easily blending i.e. chemically similar for liquids.
- Physically similar i.e. appearance, color, taste smell.

### 1.3.2 Common adulterant used in mustard oil [3]

- Palm oil (most common)
- Industrial solvents
- Soya Oil
- Rice Husk oil

## II. ANALYTICAL METHODS

### 1.3 Dissipation Factor Measurement Method (Tanδ) [4]

In oil industry we may successfully use capacitance technology to measure adulteration in vegetable oil. The usefulness of this method is because of appreciable change in relative permittivity value between vegetable oil and adulterant (soya/palm oil). The fuel cell sensor behaves like the two plates of the cylindrical capacitor and Capacitance  $C$  of fuel cell is measured by formulae

$$C = 2\pi\epsilon / \ln(b/a) \quad (1)$$

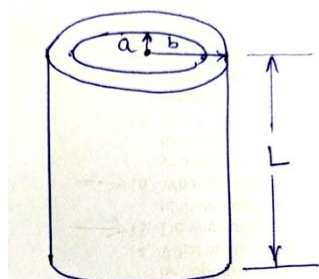

$a$  = Inner Radius  
 $b$  = Outer Radius  
 $L$  = Length of fuel cell

Fig. 1 cylindrical capacitor Sensing Element

If the amount of adulterant in fuel cell increases, effective relative permittivity of the liquid in cell increases, this causes increased capacitance of system. The measuring circuitry then compares the relation between change in capacitance and adulterant percentage. The instruments using capacitance measuring technology shows stable measurement, robust circuitry design, relatively insensitive for the conductive behavior of vegetable oils and are useful for oil based applications. Further above said set up are having lower cost set up options as compared to other measurement techniques. The demerits with capacitive

instruments are that it is very difficult to handle variable process factors and restrictions in range of measurement. These instruments use are restricted to limited range of adulterant that are under inversion point of oil and adulterant.

### 1.4 Methodology

This is a misnomer idea that the setup using capacitive technology are restricted to the linear portion of the capacitance versus percentage adulterant curve .

A Wheat stone's bridge network similar to Schering and DeSauty Bridge etc indicates the dielectric loss angle ( $\text{Tan}\delta$ ) of a sample liquid. In sensitive measurements  $\text{Tan}\delta$  is basically measured by Schering Bridge used for high voltage. But this system is not equally good for continuous measurement process.

The  $\text{Tan}\delta$  of a vegetable oil is a very important parameter which is required to be known accurately by application circuits like Schering Bridge. This bridge can measure both dielectric loss angle and relative permittivity constant with accuracy. For use in this application Schering Bridge is incorporated with Wagner earth device for accurate bridge networks measurement of  $\delta$  (loss angle) and relative permittivity constants of oil.

Because of presence of stray capacitance between output points and the accuracy in the measurement of objective parameters will be inaccurate. In Schering Bridge the measurement errors are avoided by the use of Wagner earthing mechanism. By mechanism balancing of bridge are made at Wagner earth and bridge position. Thus the output nodal points of a bridge is almost held at the same ground potential. By this measurement error because of stray capacitance is reduced.

$$\text{Tan}\delta = \epsilon''/\epsilon' [7] (2)$$

The above parameter is called loss tangent or dissipation factor, which is an indication of life expectancy of an insulation or dielectric medium. The lower the value of  $\text{Tan}\delta$  better is the life of insulation i.e. the insulation can withstand/hold electromagnetic energy by itself and there is no loss in that energy.

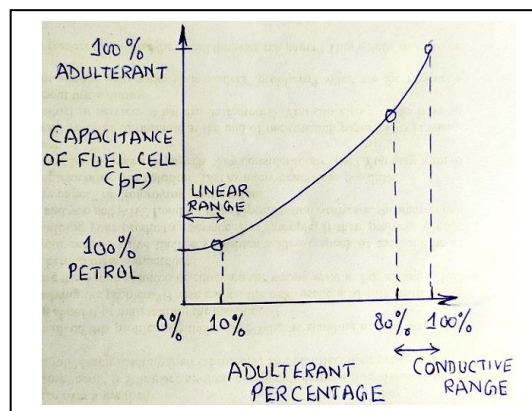

Fig. 2 fuel cell capacitance versus percentage adulterant curve [6]

In above expression  $\epsilon$  is the absolute permittivity of the capacitor fuel cell with air as dielectric medium.  $\epsilon'$  is the absolute permittivity of the capacitor fuel cell with pure petrol as dielectric medium and  $\epsilon''$  is the permittivity of the

capacitor fuel cell with adulterated petrol as dielectric medium. By comparing different values of dissipation factor the amount of adulteration can be determined.

All the dielectrics except vacuum losses of 2 types, one is a conduction loss which shows the charge flow through the dielectric while second is a dielectric loss because of rotation and movements of dipoles in a varying magnetic field.

Let us consider permittivity  $\epsilon$  is a complex number, defined as

$$\epsilon = \epsilon' - j \epsilon'' \quad (3)$$

$\epsilon'$  is the ac capacitance while  $\epsilon''$  is the dielectric loss capacitor in a good dielectric

$$\epsilon'' \gg \epsilon'. \quad (4)$$

Therefore capacitance  $C$  also becomes a complex number [8].

$$C^* = C - jC'' \quad (5)$$

In above Equation  $C^* = C$  as losses becomes zero. In complex capacitance analysis we assume a lossy capacitor.

### 2.3 Mixture Sample (Homogeneous)

The fuel cell should be feed with a standard fluid in order to have an accurate result of measured value. The major problem found in adulteration measuring in oil is because of the presence of air bubbles or foams formed during pouring of oil in the fuel cell. At that moment the capacitive fuel cell is exposed to multiple parallel and very indifferent phases. Fluid Adulteration testing circuitries are based on the single-phase measurement and now must attempt to understand a multiphase system having a free air and emulsions of oil. A multiphase process comprising mustard oil, palm oil and air bubble is to be avoided. Therefore, the adulteration device assumes a single phase measurement.

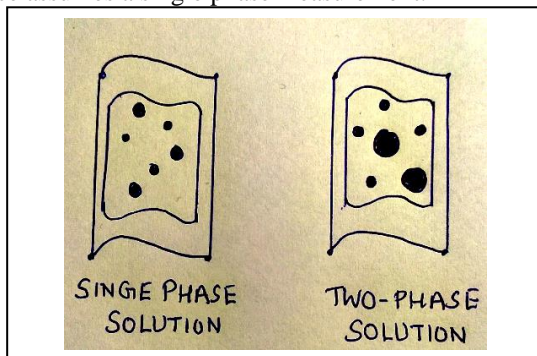

Fig. 3 single phase measurement Sample

## III. WORK PLAN

### 1.5 Fuel cell design

Various mounting options should be available. Maintaining of system must be taken into account while choosing the correct cell design. Users should ask the following questions to designer:

- What is the procedure to clean the setup and easiness in the process?

- Whether the fuel cell is meant for a particular fluid sample?
- Is there any accessories in fuel cell which require regular/intermediate inspection and maintenance?
- How well do the external electronics stand up to harsh ambient conditions?

All the above questions needs to be answered while taking a particular design for fuel cell.

### 3.2 Collection Of fuel Sample

Vegetable oils like mustard oil were bought from the reputed general stores. For the mixture preparation of mustard and palm, at least five sets of sample mixture were prepared in 1000:00, 990:10, 980:20, 970:30, and 950:50 ml volume ratios. Similarly, for preparing the mixture of mustard with soya, at least five sets of sample mixture were prepared in 1000:00, 990:10, 980:20, 970:30, and 950:50 ml volume ratios. For mustard oil and palm oil mixture preparation, at least 5 sets of sample mixture were prepared and tested.

The mixture samples created by adding palm oil into mustard oil in different ratios were used to measure dielectric properties of adulterated mixture and different sets of relative permittivity were measured. Similarly, the mixture samples prepared by mixing mustard oil and soya oil were used in fuel cell to measure the relative permittivity ( $\epsilon$ ). The measured relative permittivity ( $\epsilon$ ) is then compared with the existing standards for in-use standards.

## IV. EXPERIMENTAL SETUP

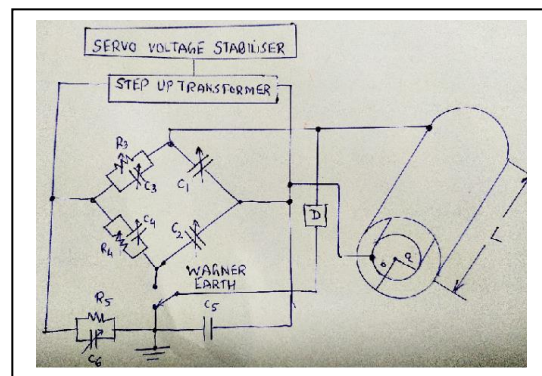

Fig. 5 Theoretical circuit diagram for Adulteration measurement.

While using this setup for using under high voltage, adequate precautions should be addresses for shielding every components of Schering Bridge and connect every shield point to ground to avoid any adverse effect to circuits, output setup as well as the human.

### GuardRings [8]

To shield some pieces of apparatus from the effect of electric static fields which are external to apparatus. This is done by surrounding the apparatus by an earthed metal

screen which may be of thin aluminum or copper sheet or in the form of wire mesh. Guard rings are used in order to overcome the fringing electrostatic field at its edges.

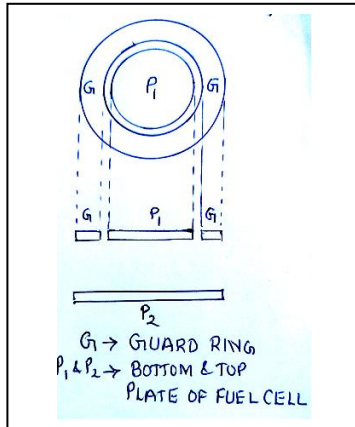

Fig. 4 Guard Ring Arrangement in Fuel Cell

The below attached figure shows the actual experimental setup that was used in laboratory for the measurement of  $\tan\delta$  and adulteration in petrol and diesel samples.

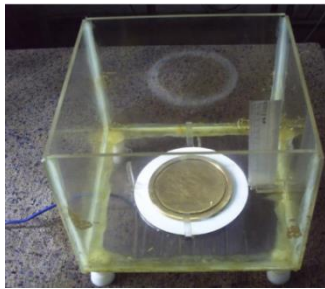

Fig. 5 Fuel Cell Bottom Part



Fig.6 Fuel Cell Top Part

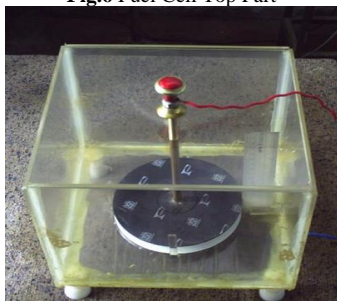

Fig. 7 Capacitor Fuel Cell



Fig.8 Complete Experimental set up

While recording observations , care must be taken to ensure that the fluid in between the plates should be one phase medium and any form of air bubbles are removed by churning the fluid ob by blowing air through it.

## 2 Observations Table

Table 1. Kerosene as an Adulterant in Diesel.

S. No.	Volume ratio (ml) (diesel:kerosene)	Capacitance of fuel cell (pf)	Relative permittivity ( $\epsilon_r$ )	Dissipation factor ( $\tan\delta$ )
1	1000:00	103.19	500.113	0.097
2	990:10	102.35	496.042	0.098
3	980:20	100.80	488.529	0.099
4	970:30	99.01	479.854	0.099
5	950:50	98.30	476.413	0.100

Table 2. Kerosene as an Adulterant in Petrol.

S. No.	Volume ratio (ml) (petrol:kerosene)	Capacitance of fuel cell (Pf)	Relative permittivity ( $\epsilon_r$ )	Dissipation factor ( $\tan\delta$ )
1	1000:00	99.89	484.119	0.100
2	990:10	99.67	483.053	0.101
3	980:20	99.55	482.471	0.102
4	970:30	96.34	466.914	0.104
5	950:50	92.53	448.449	0.108

Table 3. Diesel as an Adulterant in Petrol.

S. No.	Volume ratio (ml) (petrol:diesel)	Capacitance of fuel cell (Pf)	Relative permittivity ( $\epsilon_r$ )	Dissipation factor ( $\tan\delta$ )
1	1000:00	100.32	486.203	0.098
2	990:10	99.58	482.617	0.099
3	980:20	99.10	480.290	0.100
4	970:30	97.83	474.135	0.102
5	950:50	95.03	460.565	0.105

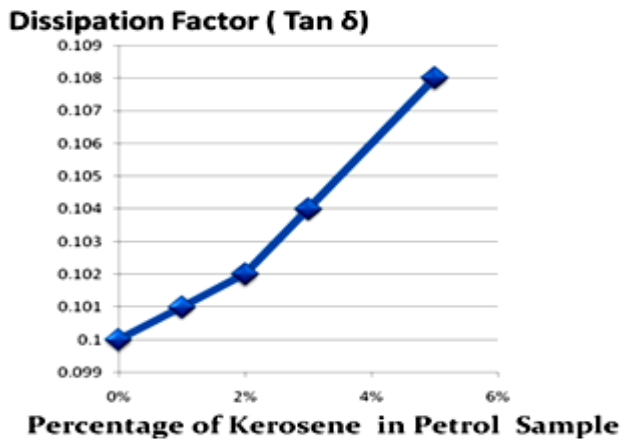

Fig.10 Dissipation Factor versus percentage of kerosene as adulterant curve

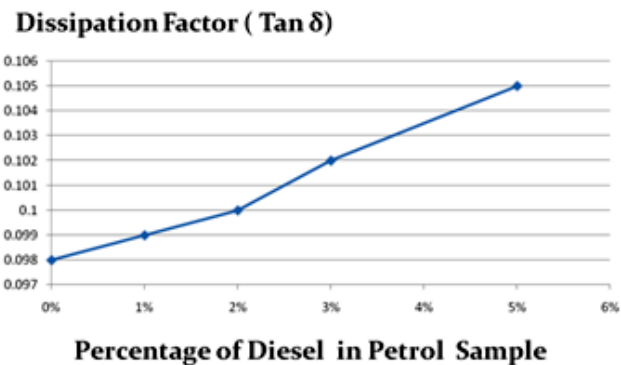

Fig.11 Dissipation Factor versus percentage of Diesel as adulterant curve

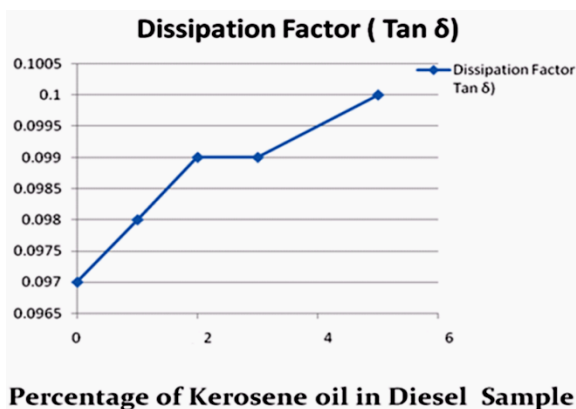

Fig.12 Dissipation Factor versus percentage of Diesel as adulterant curve.

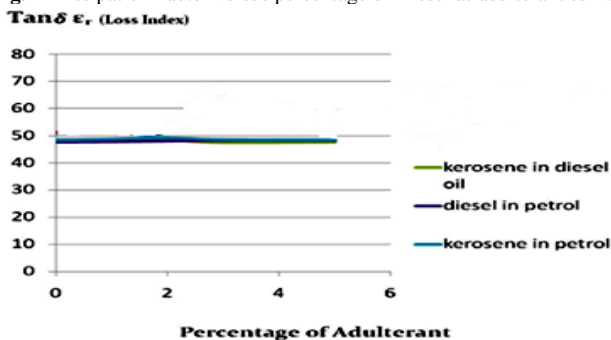

Fig 13. Loss Index versus percentage adulterant curve

## V. CONCLUSION

- From the observation table it is clear that as the percentage of adulterant increases in a sample, both capacitances of fuel cell and relative permittivity decreases but  $\tan\delta$  increases.
- But in case of kerosene adulteration with diesel though both capacitance of fuel cell and  $\epsilon_r$  decreases but there is no significant change in value of  $\tan\delta$ .
- From the final graph it is seen that loss index for petrol+kerosene, diesel + kerosene, petrol + diesel is almost constant.
- In order to achieve top performance from an adulteration monitoring setup, the operator should have adequate data on the various parameters and characteristics of final product. The monitoring systems performance must be evaluated on the accuracy, sensor range, process curves, mechanical configuration of electrodes, maintenance requirements and cost of setup before taking a decision to own it. The users of setup will be able to decide which instrument best in line with the technology.

## References

- Yadav R, Murthy K.V, Mishra D, Baral B 'Estimation of petrol and diesel adulteration with kerosene and assessment of usefulness of selected automobile fuel quality test parameters' International journal of environmental science and technology Vol. 1, NO.4, pp. 253-255, winter 2005
- Sandesh Adhikari, Food Adulteration, Types of Food Adulteration and Mitigation Measures,
- [https://www.researchgate.net/publication/43562787\\_Estimation\\_of\\_petrol\\_and\\_diesel\\_adulteration\\_with\\_kerosene\\_and\\_assessment\\_of\\_usefulness\\_of\\_selected\\_automobile\\_fuel\\_quality\\_test\\_parameters](https://www.researchgate.net/publication/43562787_Estimation_of_petrol_and_diesel_adulteration_with_kerosene_and_assessment_of_usefulness_of_selected_automobile_fuel_quality_test_parameters)
- <https://www.neetrac.gatech.edu/publications/CDFI/6-Tan-Delta-21-with-Copyright.pdf>
- <https://www.sciencedirect.com/topics/engineering/complex-permittivity>
- [https://www.researchgate.net/publication/282331690\\_Fluids\\_Adulteration\\_Identification\\_based\\_on\\_Resistive\\_and\\_Capacitive\\_Variations](https://www.researchgate.net/publication/282331690_Fluids_Adulteration_Identification_based_on_Resistive_and_Capacitive_Variations)
- [https://www.researchgate.net/publication/289455114\\_Guard\\_ring\\_effects\\_on\\_capacitive\\_transducer\\_systems](https://www.researchgate.net/publication/289455114_Guard_ring_effects_on_capacitive_transducer_systems)
- <http://www.new.dli.ernet.in/handle/2015/19585>